



CFH & WFH Hydraulic Adjusting Construction Forks



MODEL: _____

SERIAL NUMBER: _____

Rev. 10/13

Rylind Manufacturing, Inc.
2801 Youngfield Street
Suite 250
Golden, CO 80401-2263

Business/Sales Offices: 303-979-3548
Manufacturing Plant: 970-522-2859
www.Rylind.com
Info@rylind.com

- Thank you for purchasing a Rybind Attachment. For proper installation and operation for your Rybind Attachment this book **SHOULD BE READ COMPLETELY BEFORE BEGINNING INSTALLATION OR OPERATION OF THE EQUIPMENT.**
- Your safety and the safety of others depend on the proper installation, operation, maintenance, and understanding in the use of this equipment.
- Some photographs and installations in this manual may show details of this attachment that may be slightly different from your unit.
- Continuing improvements and advancements of this product may occur at any time.
- Any unauthorized modification to this product or lack of maintenance, proper use, or unsafe operating techniques will not be covered under warranty, further more Rybind Manufacturing reserves the right to void the warranty on some or all the equipment installed on that unit.
- If any questions arise during installation or maintenance of your product please consult your dealer or contact Rybind Manufacturing's corporate offices.

Thank you for your business.

Hydraulic Adjusting Construction Forks

DO NOT MODIFY ATTACHMENTS

Modification may weaken the integrity of the attachment and may impair the function, safety, life, and performance. When making repairs use only the manufacturer's genuine parts, following authorized instructions. Other parts may be substandard in fit and quality. Any modifications must be authorized in writing by Rybind to not void warranty.

SAFE OPERATION

DO NOT operate equipment until you are completely trained by a qualified operator in how to use the controls, know its capabilities, dimensions, and all safety requirements.

- Keep all step plates, slide bars, safety locks, and coupler mounts free of debris, dirt, grease, and oil.
- Never allow anyone to be around the equipment when it is operating.
- Do not operate the equipment from anywhere other than the correct operators position.
- Never leave equipment unattended with the engine running or with the attachment in a raised position
- Do not alter or remove any safety features from this attachment

SAFELY MAINTAIN AND REPAIR EQUIPMENT

- Do not wear loose clothing, or any accessories that can catch in moving parts. If you have long hair, cover or secure it so that it does not become entangled in the equipment.
- Work on a level surface in a well-lit area.
- Use properly grounded electrical outlets and tools.
- Use the correct tool for the job.
- Wear protective equipment specified by the tool manufacturer.

DO NOT IMPROPERLY USE ATTACHMENT

Rybind Forks are designed to be used as a material handling tool, loading and transporting material. Uses outside material handling must be approved by Rybind to not void warranty.

TINE CAPACITIES ARE RATED AT 24IN FROM THE RISER CENTER LOAD ON BOTH TINES

| Tine Size | Capacity |
|-----------|----------|
| 2"x5" | 8,000# |
| 2"x6" | 12,000# |
| 2.5"x6" | 18,000# |
| 3"x6" | 22,000# |
| 3"x7" | 28,000# |
| 3"x8" | 33,900# |
| 4"x8" | 40,200# |

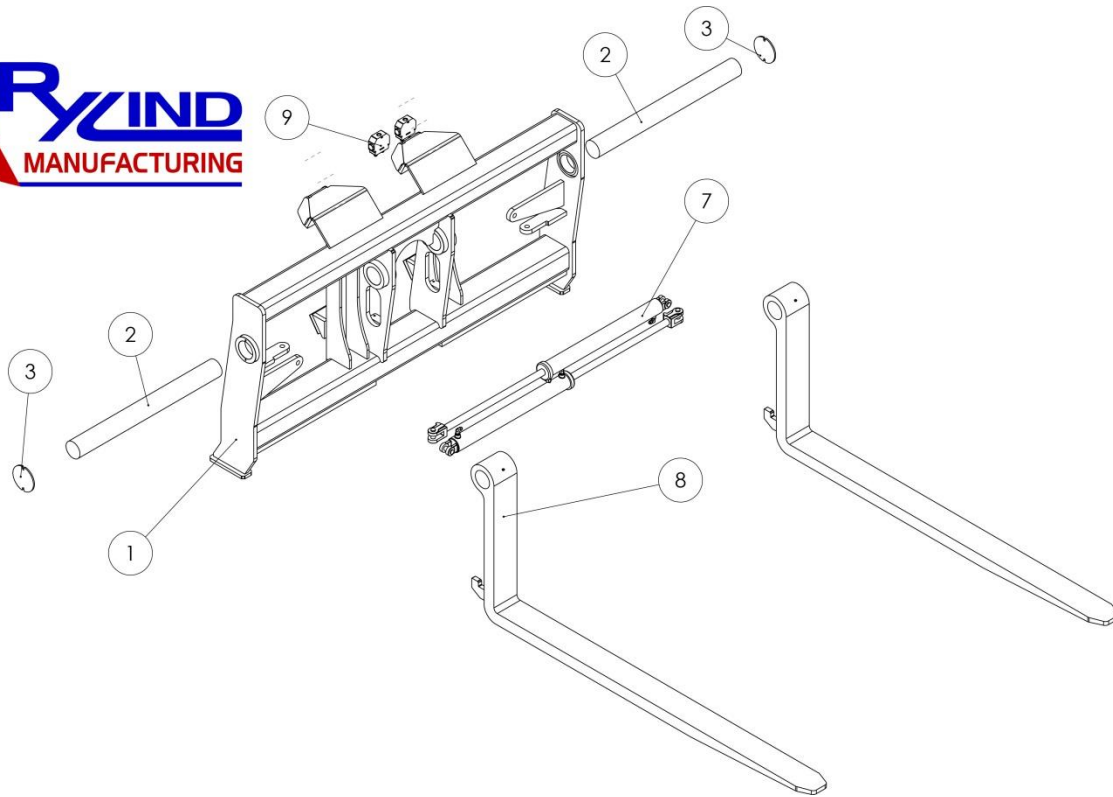

WFH 96" & 120" Wide Hydraulic Adjusting Fork

| Item | QTY | Part Number | Description |
|------|-----|----------------|------------------------------------|
| 1 | 1 | | Fork Frame |
| 2 | 2 | Model Specific | Fork Tine Slide Bar |
| 3 | 2 | Model Specific | Slide Tube Cap Plate |
| 4 | 4 | | 3/8 Flat Washer |
| 5 | 4 | 3502600021 | 3/8 Lock Washer |
| 6 | 4 | 802624402 | 3/8 Hex Head Cap Screw |
| 7 | 2 | CHF330 | 3X30 Welded Clevis Cylinder |
| 7 | 2 | PRF330 | 3X30 Welded Cylinder (Older Style) |
| 8 | 2 | Model Specific | Fork Tines (48", 60", 72", 96") |
| | 2-4 | 32002 | Tine Locks |
| 9 | 2 | RP308-8 | Hydraulic Diverter Valves |

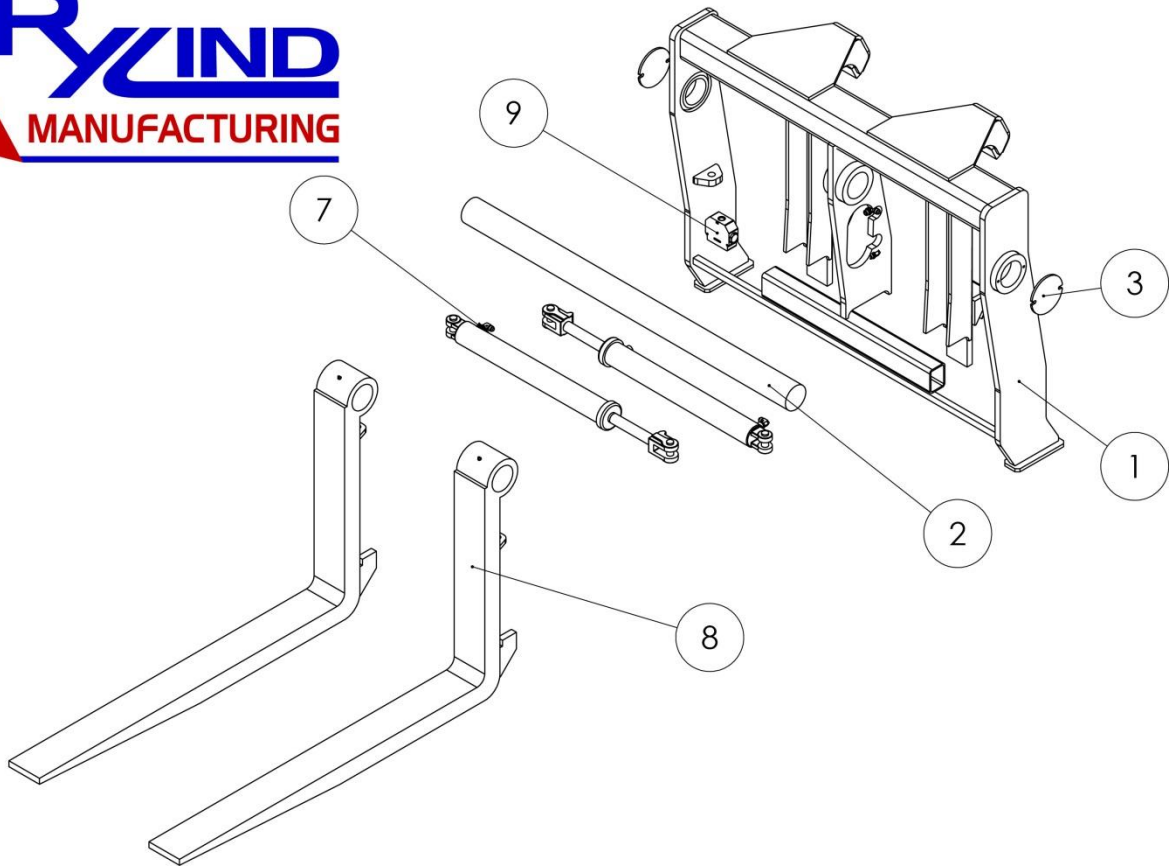

CFH 60" Wide Hydraulic Adjusting Fork

| Item | QTY | Part Number | Description |
|------|-----|----------------|------------------------------------|
| 1 | 1 | | Fork Frame |
| 2 | 1 | Model Specific | Fork Tine Slide Bar |
| 3 | 2 | Model Specific | Slide Tube Cap Plate |
| 4 | 4 | | 3/8 Flat Washer |
| 5 | 4 | 3502600021 | 3/8 Lock Washer |
| 6 | 4 | 802624402 | 3/8 Hex Head Cap Screw |
| 7 | 2 | 43024 | 3X24 Welded Clevis Cylinder |
| 7 | 2 | PRF316 | 3x16 Welded Cylinder (Older Style) |
| 8 | 2 | Model Specific | Fork Tines (48", 60", 72", 96") |
| | 2-4 | 32002 | Tine Locks |
| 9 | 1 | RP308-8 | Hydraulic Diverter Valve |

MAINTENANCE

- Grease zerks should be greased daily
- Check for cracks and or stress daily
- Check torque on all bolts
- Check tine locks and stops for excessive wear

- Grease Tine Slide Bar daily
- DO NOT OPERATE FORK WITH CRACKED TINES, replace cracked tines immediately.
- DO NOT weld on top/bottom of tine, welding will weaken the strength of the tines.

Tine Locks or Cylinder Mount Welding Guidelines for Rybind Fork Tines

- Welding on Fork Tines should only be done by a qualified welder.
 - a) Tacking
 1. Never Tack Fork Tines without first preheating the area to 200°F (94°C)
 - b) Preheating
 1. As with standard welding procedures, the preheated temperature is 600°F (316°C). Extreme care must be taken not to exceed this temperature to avoid compromising the integrity of the fork tine.
 2. Use a soft flame and do not leave unattended
 3. Use a 600°F tempil stick frequently on the heated surface until it melts.

Note: As well as soft spots, overheating and welding at elevated temperatures causes poor welds.
 - c) Welding
 1. Use standard welding procedures. All welders must be qualified welders
 2. Do not weld top and bottom of tine locks, sides only.
 - d) Post Heating
 1. In all cases where practical, the parts are to be drawn as per standard procedures and temperatures as per heat treatment practices.
 2. Where this is not practical and/or desirable, the parts shall be post heated with a soft flame. This process must be conducted under supervision and as per the preheat procedures, except the temperature as per the draw temperatures 850°F (454°C). The tempil sticks must be to equivalent levels.

NO WELDING IS TO BE CONDUCTED ON THE TOP SURFACES OF A FORK

NO WELDING IS TO BE CONDUCTED IN THE INSIDE RADIUS OF THE HEEL UNDER ANY CIRCUMSTANCES

- e) Once the Weld has cooled, the weld and material should be examined for cracks using a non-destructive method. Preferably the crack detection should take place after a 12 hour delay.



Business Offices Only
2801 Youngfield Street
Suite 250
Golden, CO 80401-2263

P) 303-979-3548
F) 303-979-4730
www.Rylind.com
Info@rylind.com

LIMITED WARRANTY

Rylind Manufacturing Inc. Is a company related to and having the responsibility for the manufacturing, marketing, and distribution of the product line known by the registered trade name "Rylind"

Rylind Manufacturing, Inc. warrants these products to be free of defects in material and/or workmanship for a period of one (1) year or 2,000 hours from the date of purchase under normal use and service providing that:

- A. All products and related components are installed properly according to instructions and that proper maintenance and greasing of movable parts is completed on a regular basis.
- B. The attachment products and related components are used only for the purpose for which they were intended as designated by the manufacturer and that the rated capacities are not exceeded.
- C. This is a "PARTS ONLY" warranty for defects in hydraulic components not typical maintenance parts (i.e. seal kits, hydraulic hoses, cylinders, or vendor supplied valves). This means the hydraulic part will be replaced freight prepaid from the factory. Travel time or labor to replace the defective component is "NOT" included in this warranty. Return of the defective parts for inspection may be requested.
- D. Hydraulic kits and components are warranted for one (1) year from invoice date. Cylinders must be returned in their entirety and not have been disassembled to be considered for warranty. After warranty replacement parts include cylinders, hydraulic valves, seal kits, electric components, and wear parts are warranted for 90 days from the date of purchase. Disassembly, modification or welding of any kind without the written permission of Rylind Manufacturing voids the warranty on the cylinder and seals. All warranty components must be packaged and sealed to avoid contaminants from entering during shipping. Improperly packaged components will not be considered for warranty. Hydraulic hoses are warranted against failure due to workmanship. Improper installation, ripping, cutting, or wear due to rubbing is not covered under warranty.
- E. Defects in materials and/or workmanship with respect to welding or structural failures will be paid at a rate not to exceed 70% of the advertised charge out rate. Repairs must be authorized by Rylind before work proceeds. Travel time or mileage is "NOT" included. All warranty work to be performed must be authorized by Rylind Manufacturing, Inc. Repair or replacement will be at our discretion. Estimates of the total costs involved must be given to us before proceeding with any work involving a Rylind product. No warranty will apply to products that have been modified or repaired without our authorization. Normal wear and tear will not be considered as a defect. Accidents, misuse or negligence does not justify warranty. This warranty does not

include or cover purchased subassemblies including, but not limited to, teeth, fork tines, cylinders, wear plates, edges, etc... Such purchased subassemblies are covered only by the OEM's warranty, if any, of their respective manufacturer, and not Rybind Manufacturing.

F. Limitations

- a. This limited warranty does not cover product, which in the opinion of Rybind, is damaged due to abuse, misuse, misapplication, prohibited operation, improper maintenance, alteration, unauthorized service, contamination by the base machine, or normal wear and tear. This warranty is null and void if the product is modified in any way without the written consent or instruction of Rybind.
 - b. This limited warranty is null and void if the product is used in a prohibited operation, or unauthorized adjustment/assembly/disassembly has occurred.
 - c. Dealers or Agents of Rybind have no authority to make any type of representation or warranties on behalf of Rybind Manufacturing beyond those expressly set forth in this document.
 - d. This warranty is in lieu of and excluding all other warranties preceding it including and without limitation to any implied warranties of merchantability or fitness for a particular purpose.
- G. In no event shall Rybind be liable to any party, including but not limited to buyer for any direct, incidental, consequential, punitive, or special damages, including but not limited to loss of profits, loss of productivity, in any way related to or arising, directly or indirectly from the product. The liability of Rybind for any and all losses and damage to buyer, its successors and assigns, resulting from any cause whatsoever, including the negligence of Rybind, irrespective of whether such defects are discoverable or latent, shall in no event exceed the purchase price of the product with respect to which such losses or damages are claimed.
- H. All returned products must be shipped to the following address to avoid any delay or expense in the warranty process:

Rybind Manufacturing, Inc.
Warranty/Service Department
16178 Front Ave
Atwood, CO 80722