



MG1A Parallel Lift Group



Model: _____

Serial Number: _____

Rev. 10/13

Rylind Manufacturing, Inc.
2801 Youngfield St
Suite 250
Golden, CO 80401

Main Offices: 303-979-3548
Manufacturing Plant: 970-522-2859
www.Rylind.com
Info@rylind.com

- Thank you for purchasing a Rybind Attachment. For proper installation and operation for your Rybind Attachment this book **SHOULD BE READ COMPLETELY BEFORE BEGINNING INSTALLATION OR OPERATION OF THE EQUIPMENT.**
- Your safety and the safety of others depend on the proper installation, operation, maintenance, and understanding in the use of this equipment.
- Some photographs and installations in this manual may show details of this attachment that may be slightly different from your unit.
- Continuing improvements and advancements of this product may occur at any time.
- Any unauthorized modification to this product or lack of maintenance, proper use, or unsafe operating techniques will not be covered under warranty, further more Rybind Manufacturing reserves the right to void the warranty on some or all the equipment installed on that unit.
- If any questions arise during installation or maintenance of your product please consult your dealer or contact Rybind Manufacturing's corporate offices.

Thank you for your business.

Front Mount Parallel Lift Group

Rylind Manufacturing's Parallel Lift Group interchanges with attachments setup for a Balderson Style Lift Group. Lift Groups can be used with Quick Mount Scarifiers, V-Plows, Angle Dozer Blades, Angle Ramp Plows, Reversing Tripping Plows, Straight Dozer Blades, and many other attachments.

Manual-Locking hitch pins with clasps is standard. Hydraulic Locking Options available and requires one extra auxiliary hydraulic valve for operation. Hydraulic/Electric split valve available for graders that do not have an open valve for operation.

Maintenance

Any damaged components, bends, cracked welds, or hydraulic leaks need to be fixed immediately. It is recommended to re-torque all bolts after the first 8 hours, and to regularly check for loose and/or missing fasteners. Replace any damaged or missing fasteners immediately.

Because of the environment that Motor Graders operate in damage to hydraulic lines, fasteners, and other items may occur. These times must be inspected and replaced if necessary to avoid damage or personal injury.

Lubrication of moving parts is extremely important. Snow, Ice, salt, and road debris can and will wash away lubrication and it may be necessary to inspect and reapply more lubrication more than once a day.

IN-SEASON MAINTENANCE

- 1. Discontinue use immediately if any problems are found.**
2. Before each operation inspect the lift group for any stress, cracks, broken parts, or leaking cylinders.
3. Remove and inspect lift group pins for stress fractures every 40 hours of operation.
4. Grease all lift group pins before each use.
5. Remove and inspect manual locking pins or hydraulic lock pins for stress fractures every 40 hours of operation.



MG1A Parts List

MG1A – Motor Grader Lift Group Parts

#	# Required	Part Number	Description
1	1	27951	5" Cylinder Complete
2	1	27952	5" Cylinder Seal Kit
3	1	27953-CT	Grader Back Plate - CAT
3	1	27953-CNH	Grader Back Plate - CASE/New Holland
3	1	27953-JD	Grader Back Plate - John Deere
3	1	27953-KM	Grader Back Plate - Komatsu
3	1	27953-VME	Grader Back Plate - Volvo
3	1	27953	Grader Back Plate - Other
4	1	27954	Balderson Style Coupler Head
5	2	27956	Upper Lift Arms
6	1	27957	Lower Lifting Assembly
7	5	27958	Lifting Assembly & Cylinder Barrel Pins
8	1	27959	Cylinder Rod Pin with Snap Rings
9	1	27960	2" Safety Lock Pin
10	1	27961	Safety Lock Catch
11	2	CO-10022	1-1/2" MG1A/MG2A Manual Hitch Pin

Optional Hydraulic Locking Pin Parts

#	# Required	Part Number	Description
13	1	27772	Locking Cylinder Bracket
14	1	18240	Double Lock Pin Cylinder Complete
15	2	18241	Locking Pins
16	2	N/A	Lock Pin Bolt
17	1	18265	Locking Cylinder Seal Kit
18	1	18246	Hydraulic/Electric Selector Valve Kit, 30GPM to split one auxiliary function into two.

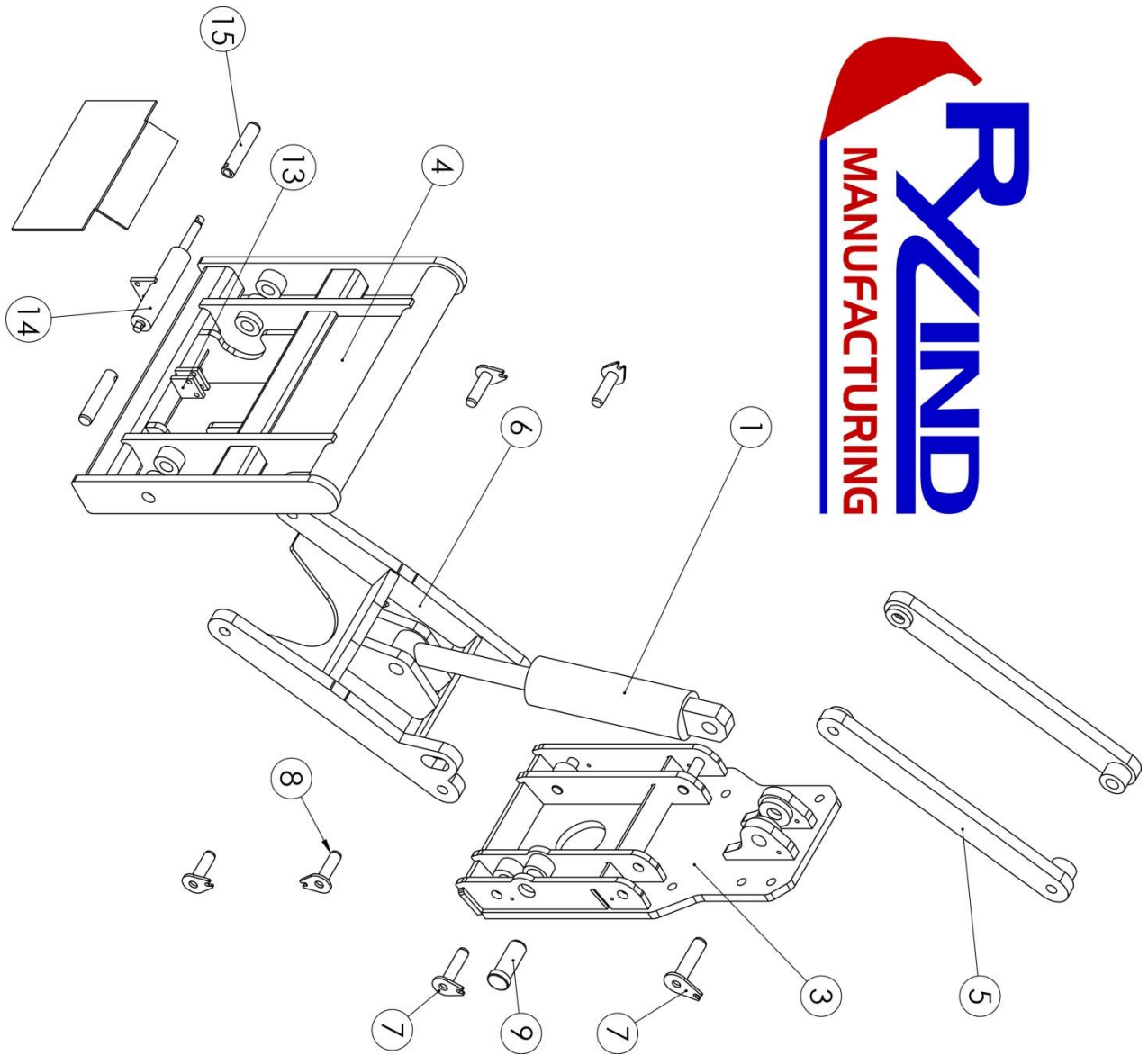

*Image may not reflect current design



Business Offices Only
2801 Youngfield St
Suite 250
Golden, CO 80401

P) 303-979-3548
F) 303-979-4730
www.Rylind.com
Info@rylind.com

LIMITED WARRANTY

Rylind Manufacturing Inc. Is a company related to and having the responsibility for the manufacturing, marketing, and distribution of the product line known by the registered trade name "Rylind"

Rylind Manufacturing, Inc. warrants these products to be free of defects in material and/or workmanship for a period of one (1) year or 2,000 hours from the date of purchase under normal use and service providing that:

- A. All products and related components are installed properly according to instructions and that proper maintenance and greasing of movable parts is completed on a regular basis.
- B. The attachment products and related components are used only for the purpose for which they were intended as designated by the manufacturer and that the rated capacities are not exceeded.
- C. This is a "PARTS ONLY" warranty for defects in hydraulic components not typical maintenance parts (i.e. seal kits, hydraulic hoses, cylinders, or vendor supplied valves). This means the hydraulic part will be replaced freight prepaid from the factory. Travel time or labor to replace the defective component is "NOT" included in this warranty. Return of the defective parts for inspection may be requested.
- D. Hydraulic kits and components are warranted for one (1) year from invoice date. Cylinders must be returned in their entirety and not have been disassembled to be considered for warranty. After warranty replacement parts include cylinders, hydraulic valves, seal kits, electric components, and wear parts are warranted for 90 days from the date of purchase. Disassembly, modification or welding of any kind without the written permission of Rylind Manufacturing voids the warranty on the cylinder and seals. All warranty components must be packaged and sealed to avoid contaminants from entering during shipping. Improperly packaged components will not be considered for warranty. Hydraulic hoses are warranted against failure due to workmanship. Improper installation, ripping, cutting, or wear due to rubbing is not covered under warranty.
- E. Defects in materials and/or workmanship with respect to welding or structural failures will be paid at a rate not to exceed 70% of the advertised charge out rate. Repairs must be authorized by Rylind before work proceeds. Travel time or mileage is "NOT" included. All warranty work to be performed must be authorized by Rylind Manufacturing, Inc. Repair or replacement will be at our discretion. Estimates of the total costs involved must be given to us before proceeding with any work involving a Rylind product. No warranty will apply to products that have been modified or repaired without our authorization. Normal wear and tear will not be considered as a defect. Accidents, misuse or negligence does not justify warranty. This warranty does not

include or cover purchased subassemblies including, but not limited to, teeth, fork tines, cylinders, wear plates, edges, etc... Such purchased subassemblies are covered only by the OEM's warranty, if any, of their respective manufacturer, and not Rybind Manufacturing.

F. Limitations

- a. This limited warranty does not cover product, which in the opinion of Rybind, is damaged due to abuse, misuse, misapplication, prohibited operation, improper maintenance, alteration, unauthorized service, contamination by the base machine, or normal wear and tear. This warranty is null and void if the product is modified in any way without the written consent or instruction of Rybind.
 - b. This limited warranty is null and void if the product is used in a prohibited operation, or unauthorized adjustment/assembly/disassembly has occurred.
 - c. Dealers or Agents of Rybind have no authority to make any type of representation or warranties on behalf of Rybind Manufacturing beyond those expressly set forth in this document.
 - d. This warranty is in lieu of and excluding all other warranties preceding it including and without limitation to any implied warranties of merchantability or fitness for a particular purpose.
- G. In no event shall Rybind be liable to any party, including but not limited to buyer for any direct, incidental, consequential, punitive, or special damages, including but not limited to loss of profits, loss of productivity, in any way related to or arising, directly or indirectly from the product. The liability of Rybind for any and all losses and damage to buyer, its successors and assigns, resulting from any cause whatsoever, including the negligence of Rybind, irrespective of whether such defects are discoverable or latent, shall in no event exceed the purchase price of the product with respect to which such losses or damages are claimed.
- H. All returned products must be shipped to the following address to avoid any delay or expense in the warranty process:

Rybind Manufacturing, Inc.
Warranty/Service Department
16178 Front Ave
Atwood, CO 80722