



**HEAVY & SEVERE DUTY  
RPD ANGLE SNOW PLOW**



Model: \_\_\_\_\_

Serial Number: \_\_\_\_\_

Rev. 01/18

<p>Rylind Manufacturing, Inc. 2801 Youngfield St Suite 250 Golden, CO 80401</p>	<p>Main Offices: 303-979-3548 Manufacturing Plant: 970-522-2859 <a href="http://www.Rylind.com">www.Rylind.com</a> Info@rylind.com</p>
---	--

Thank you for purchasing a Rybind Attachment. For proper installation and operation for your Rybind Attachment this book **SHOULD BE READ COMPLETELY BEFORE BEGINNING INSTALLATION OR OPERATION OF THE EQUIPMENT.**

- Your safety and the safety of others depend on the proper installation, operation, maintenance, and understanding in the use of this equipment.
- Some photographs and installations in this manual may show details of this attachment that may be slightly different from your unit.
- Continuing improvements and advancements of this product may occur at any time.
- Any unauthorized modification to this product or lack of maintenance, proper use, or unsafe operating techniques will not be covered under warranty, further more Rybind Manufacturing reserves the right to void the warranty on some or all the equipment installed on that unit.
- If any questions arise during installation or maintenance of your product please consult your dealer or contact Rybind Manufacturing's corporate offices.

Thank you for your business.

# Maintenance

---

Rylind RPD Heavy and Severe Duty Snow Plow must be maintained regularly during in season use. Inspection must be carried out every 8 hour of operation. Any damaged components, bends, cracked welds, or hydraulic leaks need to be fixed immediately. It is recommended to re-torque all bolts after the first 8 hours, and to regularly check for loose and/or missing fasteners. Replace any damaged or missing fasteners immediately.

Because of the environment that snow equipment operates in. Damage to hydraulic lines, fasteners, wearable and replaceable items may occur. These times must be inspected and replaced if necessary to avoid damage or personal injury.

Lubrication of moving parts is extremely important. Snow, ice, salt, and road debris can and will wash away lubrication and it may be necessary to inspect and reapply more lubrication more than once a day.

Rylind Plows are not intended for use in the Wheel Loaders full dump position. DO NOT operate plow while in full dump for any reason. Rylind Plows are not designed to be used to pull vehicles and other objects out of stuck positions, any damage as a result will not be covered under warranty.

## END OF SEASON MAINTENANCE

1. Replace any broken cutting edges, uneven or excessively worn down cutting edges, and any broken wear guards.
2. Replace broken or missing mushroom skid shoes or blade mounted skid shoes.
3. Replace any missing or broken bolts. Use Grade 8 plow bolts on steel cutting edges.
4. Plug or cap any QC Fittings or open hose ends, inspect hoses for any leaks or cracks, secure hoses to A-Frame when storing plow.
5. Check Cylinder for leaks or any damage to chrome rod ends. Lightly greasing exposed rod ends is recommended when storing plow.
6. Check pins, bushings, and pivot bolts on plow moldboard and a-frame. Replace any damaged or worn parts.
7. Check plow for any fatigue or cracked welds
8. **Replace all worn or broken parts found before storing plow.**

## Parts List

#	# Required	Part Number	Description
1	1	Varies	Moldboard
2	2	10-400	Heavy Duty Cylinder Rod Pin
2	2	11-400	Severe Duty Cylinder Rod Pin*
3	1	EKRPD__	RPD Plow Edge Kit (Depends on Plow Size)
4	1	HDWRPD__	RPD Plow Hardware
5	1	10-401	Hinge Pin Lock Bolt
6	1	11-202	3" Heavy & Severe Duty Center Hinge Pin* (Non-Oscillating)
6B	1	11-203	3" Center Hinge Pivot Tube (Non-Oscillating)
7	1	10-RPDA	Heavy Duty A-Frame (No Mounts)
7	1	11-RPDA	Severe Duty A-Frame (No Mounts)
7	1	10-RPDAO	Heavy Duty A-Frame Oscillation (No Mounts)
7	1	11-RPDAO	Severe Duty A-Frame Oscillation (No Mounts)
8	2	PR424	4" x 24" Heavy Duty Plow Cylinder
8	2	DFP524	5" x 24" Severe Duty Plow Cylinder
8	2	PR424-SK	4" x 24" Seal Kit for PR424 Cylinder
8	2	5X24DFPSK	5" x 24" Seal Kit for DFP524 Cylinder
	4	SS-4856-24	Bronze Wear Bushings for DFP524 (2 Per Side)
9	2	10-403	Cylinder Barrel End Pin
9	2	11-403	Severe Duty Cylinder Barrel End Pin*
10	2	10-404	Moldboard Cylinder Mounting Plate
11	1	DWV-10-2500	2500 PSI Flow Control Valve
12	1	10-405	A-Frame Oscillation Barrel End Assembly
13	1	10-406	A-Frame Oscillation Mounting Pin
14	1	2315000020	Mounting Pin Castle Nut
15	1	CPP3754000	3/8X4 Cotter Pin
16	2	10-210	Center Pin Top Mounting Plate Outside Gusset
17	1	10-211	Center Pin Top Mounting Plate Center Gusset
18	1	10-212	Center Pin Top Mounting Plate
19	1	10-213	Center Pin Bottom Mounting Plate
20	2	10-214	Center Pin Bottom Plate Gusset
21	1	10-440	LH Top Cylinder Rod Mounting Point
22	1	10-441	LH Bottom Cylinder Rod Mounting Point
23	1	10-442	RH Top Cylinder Rod Mounting Point
24	1	10-443	RH Bottom Cylinder Rod Mounting Point
60	2	10-445	A-Frame Angle Stops
61	2	UH354	Oscillation UHMW Angle Wear Stop

\_\_ (Designates Number in feet for Size of Plow); (\* Severe Duty Plows Only)

### Mushroom Skid Shoe Parts (Per Side)

#	# Required	Part Number	Description
40	1	RS29-1	Skid Shoe Moldboard Bracket
41	1	RS29-2	Skid Shoe Outer Adjusting Tube
42	1	RS29-3	Skid Shoe Inner Adjusting Tube
43	1	BC-10MUSH	Mushroom Skid Shoe
44	2	DIS-06533	5/8"x2" GR8 Scraper Bolt
45	2	2063000021	5/8" Nut
46	2	3503000021	5/8" Lock Washer
47	6	503024021	1/2"x2" Hex Head Bolt
48	6	2062800021	1/2" Nut
49	6	3502800020	1/2" Lock Washer
50	1	T3899760	3/4" Adjusting Hitch Pin

### Heavy Duty Moldboard Oscillation Parts

#	# Required	Part Number	Description
25	1	10-500	Oscillation Moldboard Mount Plate
26	4	10-501	Weld-on Rotation Stops
27	1	10-502	Moldboard Top Spacer Plate 7/8
28	1	10-503	Moldboard Bottom Spacer Plate
29	2	10-504	Oscillation Plate w/Center Pin Brackets
30	2	10-505	Bolt on Top Mounting Cleat
31	1	10-506	Bolt on Bottom Mounting Cleat
6	1	10-507	Center Hinge Pin
32	13	3503400401	7/8 Lock Washer
33	13	803426402	7/8-9X2-1/2 GR8 Hex Head Bolt

### Severe Duty Moldboard Oscillation Parts

#	# Required	Part Number	Description
25	1	11-500	Oscillation Moldboard Mount Plate
26	4	11-501	Weld-on Rotation Stops
27	1	11-502	Moldboard Top Spacer Plate 7/8
28	1	11-503	Moldboard Bottom Spacer Plate
29	2	11-504	Oscillation Plate w/Center Pin Brackets
30	1	11-505	Bolt on Top Mounting Cleat
31	2	11-506	Bolt on Bottom Mounting Cleat
6	1	11-507	Center Hinge Pin
32	13	3503400401	7/8 Lock Washer
33	13	803426402	7/8-9X2-1/2 GR8 Hex Head Bolt

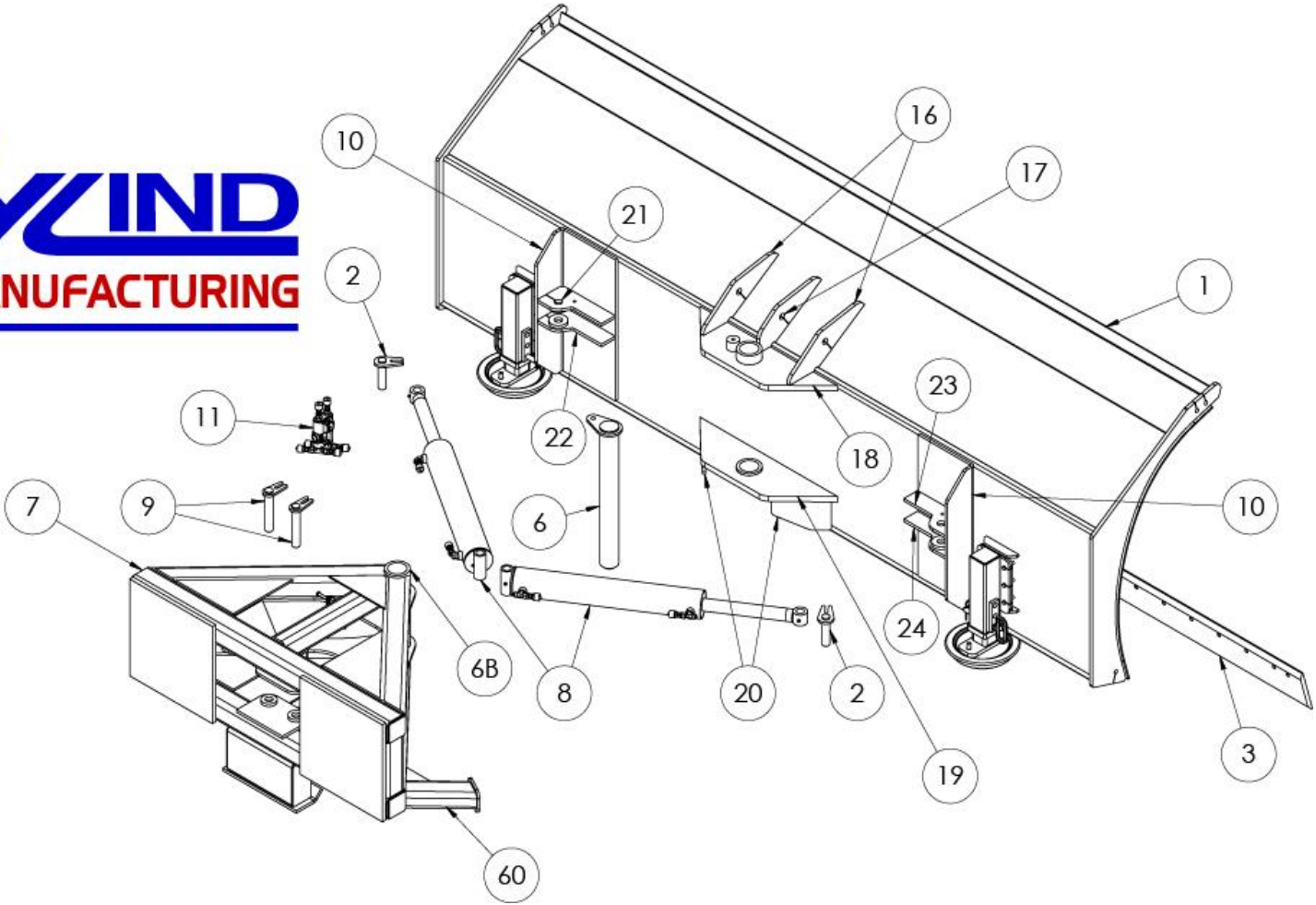

RPD Oscillating

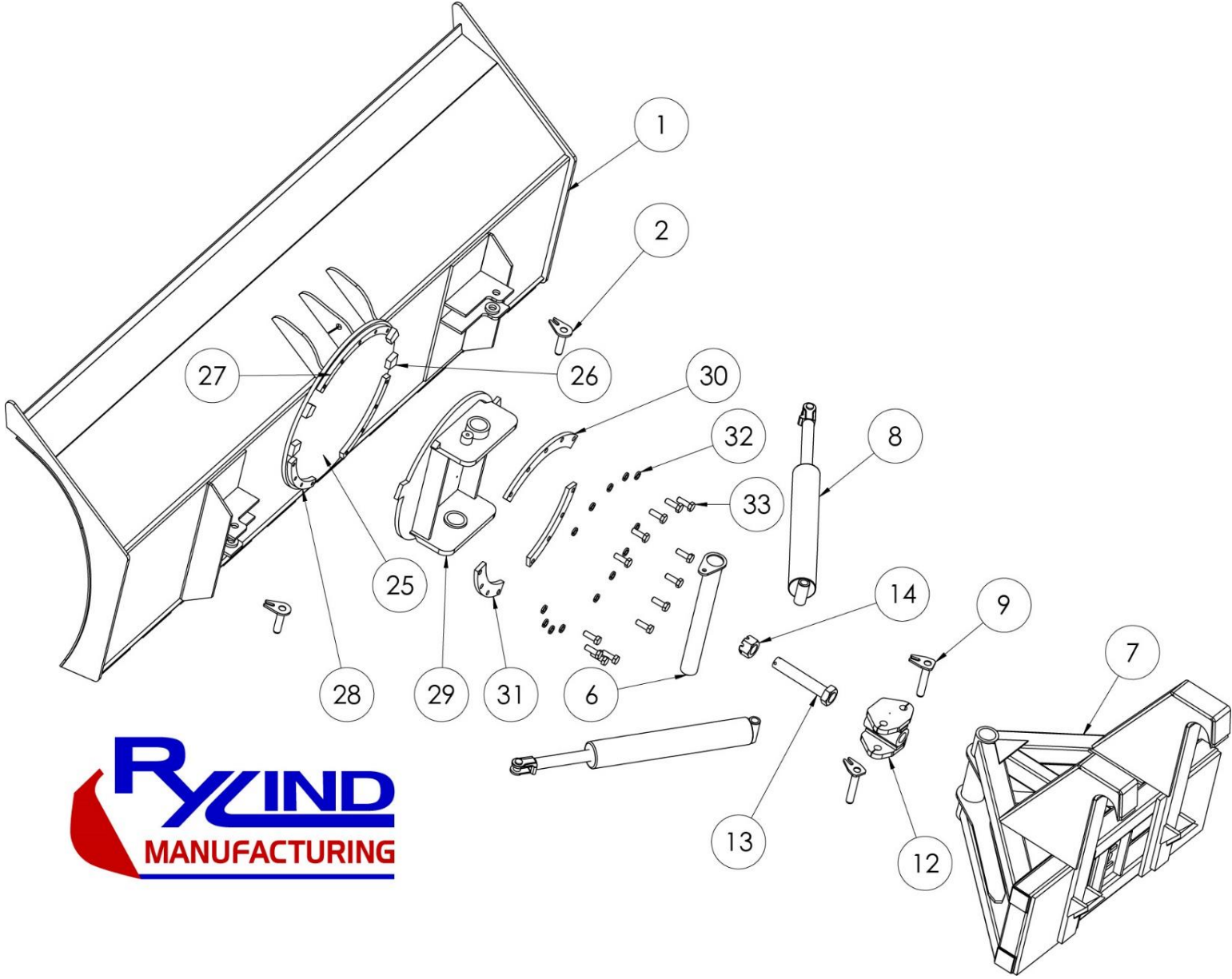

\*Plow Design May Vary



Business Offices Only  
2801 Youngfield St  
Suite 250  
Golden, CO 80401

P) 303-979-3548  
F) 303-979-4730  
[www.Rylind.com](http://www.Rylind.com)  
Info@rylind.com

## LIMITED WARRANTY

**Rylind Manufacturing Inc.** Is a company related to and having the responsibility for the manufacturing, marketing, and distribution of the product line known by the registered trade name "Rylind"

**Rylind Manufacturing, Inc.** warrants these products to be free of defects in material and/or workmanship for a period of one (1) year or 2,000 hours from the date of purchase under normal use and service providing that:

- A. All products and related components are installed properly according to instructions and that proper maintenance and greasing of movable parts is completed on a regular basis.
- B. The attachment products and related components are used only for the purpose for which they were intended as designated by the manufacturer and that the rated capacities are not exceeded.
- C. This is a "PARTS ONLY" warranty for defects in hydraulic components not typical maintenance parts (i.e. seal kits, hydraulic hoses, cylinders, lights, wiring, or vendor supplied valves). This means the hydraulic part will be replaced freight prepaid from the factory. Travel time or labor to replace the defective component is "NOT" included in this warranty. Return of the defective parts for inspection may be requested.
- D. Hydraulic kits and components are warranted for one (1) year from invoice date. Cylinders must be returned in their entirety and not have been disassembled to be considered for warranty. After warranty replacement parts include cylinders, hydraulic valves, seal kits, electric components, and wear parts are warranted for 90 days from the date of purchase. Disassembly, modification or welding of any kind without the written permission of Rylind Manufacturing voids the warranty on the cylinder and seals. All warranty components must be packaged and sealed to avoid contaminants from entering during shipping. Improperly packaged components will not be considered for warranty. Hydraulic hoses are warranted against failure due to workmanship. Improper installation, ripping, cutting, or wear due to rubbing is not covered under warranty.
- E. Defects in materials and/or workmanship with respect to welding or structural failures will be paid at a rate not to exceed 70% of the advertised charge out rate. Repairs must be authorized by Rylind before work proceeds. Travel time or mileage is "NOT" included. All warranty work to be performed must be authorized by Rylind Manufacturing, Inc. Repair or replacement will be at our discretion. Estimates of the total costs involved must be given to us before proceeding with any work involving a Rylind product. No warranty will apply to products that have been modified or repaired without our authorization. Normal wear and tear will not be considered as a defect. Accidents, misuse or negligence does not justify warranty. This warranty does not

include or cover purchased subassemblies including, but not limited to, teeth, fork tines, cylinders, wear plates, edges, etc... Such purchased subassemblies are covered only by the OEM's warranty, if any, of their respective manufacturer, and not Rybind Manufacturing.

F. Limitations

- a. This limited warranty does not cover product, which in the opinion of Rybind, is damaged due to abuse, misuse, misapplication, prohibited operation, improper maintenance, alteration, unauthorized service, contamination by the base machine, or normal wear and tear. This warranty is null and void if the product is modified in any way without the written consent or instruction of Rybind.
  - b. This limited warranty is null and void if the product is used in a prohibited operation, or unauthorized adjustment/assembly/disassembly has occurred.
  - c. Dealers or Agents of Rybind have no authority to make any type of representation or warranties on behalf of Rybind Manufacturing beyond those expressly set forth in this document.
  - d. This warranty is in lieu of and excluding all other warranties preceding it including and without limitation to any implied warranties of merchantability or fitness for a particular purpose.
- G. In no event shall Rybind be liable to any party, including but not limited to buyer for any direct, incidental, consequential, punitive, or special damages, including but not limited to loss of profits, loss of productivity, in any way related to or arising, directly or indirectly from the product. The liability of Rybind for any and all losses and damage to buyer, its successors and assigns, resulting from any cause whatsoever, including the negligence of Rybind, irrespective of whether such defects are discoverable or latent, shall in no event exceed the purchase price of the product with respect to which such losses or damages are claimed.
- H. All returned products must be shipped to the following address to avoid any delay or expense in the warranty process:

**Rybind Manufacturing, Inc.**  
**Warranty/Service Department**  
**16178 Front Ave**  
**Atwood, CO 80722**